

Beamline practice at BL01B1 (XAFS)

. K. Kato, K. Nitta, T. Uruga (JASRI)

1. Introduction

The bending magnet beamline, BL01B1, is used for various applications of XAFS over a wide energy range from 3.8 to 113 keV. In the practical training course, we plan to show how to measure XAFS spectra, which covers alignment of X-ray optics and sample position. We will also demonstrate in-situ time-resolved quick scanning XAFS measurement of catalyst samples under reaction condition.

2. Plan of practice

- 9:00-** Introduction of beamline, alignment of optics, measurement system and major scientific activities at BL01B1.
- 10:00-** Alignment of the x-ray optics.
- 11:00-** Setup of the measurement system for Quick XAFS in transmission mode.
- 11:30-** X-ray energy calibration using standard sample.
- 12:00-** Introduction of preliminary process of XAFS spectra using software ATHENA.
- 12:30-** ----- Lunch -----
- 13:30-** Introduction of in-situ XAFS experiment and sample preparation.
- 14:00-** Setup of in-situ XAFS experiment system.
- 15:00-** Measurement of in-situ XAFS spectra of catalysts during reduction process.
During the measurement, data treatment and preliminary analysis of XAFS spectra.
- 17:00** Close.

3. Alignment of x-ray optics and experimental stage

- Figure 1 shows schematic layout of BL01B1.
- Main operation in alignment of x-ray optics is follows.
 - Switch of diffraction plane of monochromator crystals between Si(111), Si(311) and Si(511) to cover energy range for XAFS measurements.
 - Change of glancing angle of mirror to remove higher-harmonic x-rays.
- Above operation slightly changes beam height downstream of monochromator.
- Fine adjustment of slits and mirrors in the optics hutch is done by measuring x-ray intensity using 1st ionization chamber in the experimental hutch (Fig. 2).
- The height of experimental stage in the experimental hutch is adjusted to x-ray beam by scanning in vertical direction.
- Fixed beam condition is achieved by adjusting the rotation angle of 1st crystal of monochromator around beam axis to 2nd crystal.
- The control program for operation of x-ray optics realizes following x-ray beam.
 - Quite low contamination ($<10^{-5}$) of higher harmonics.
 - Fixed beam position during XAFS scans passing through the center of slits in the experimental hutch.
 - Focused beam in vertical direction (0.1-0.2 mm).
- In the BL practice, the participants will align the optics following the manual upped on the WEB site, <http://bl01b1.spring8.or.jp/BL01B1opticsmanEng040213.html>.

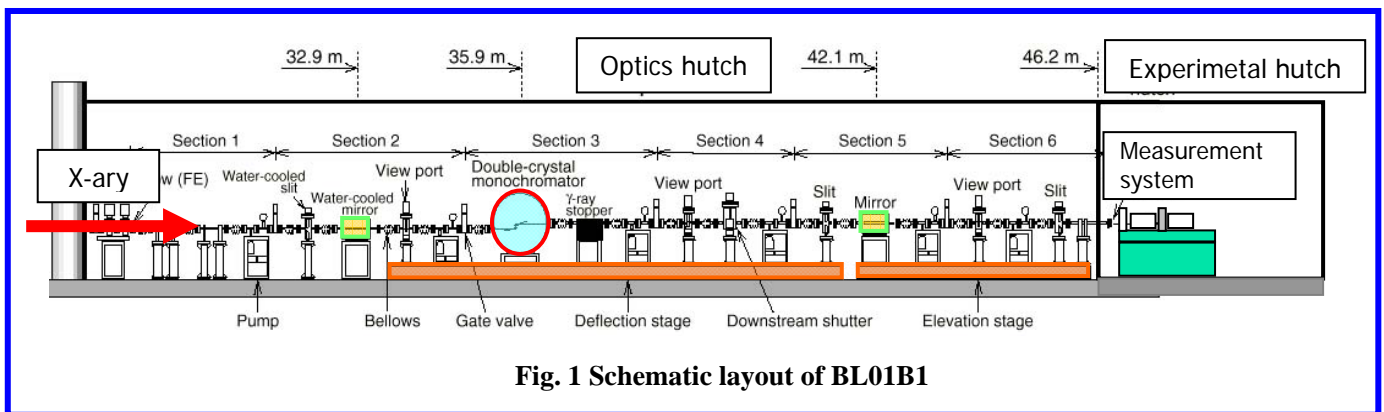

Fig. 1 Schematic layout of BL01B1

4. Quick XAFS measurement in transmission mode

- Quick XAFS measurement is realized by data storage of x-ray detector output signals and Bragg angles of monochromator in each memory board during continuous scanning.
- The arrangement and control system for transmission mode Quick XAFS measurements are shown in Figs. 2 and 3.
- Setup the ionization chambers.
 - Select and flow adequate gases for ionization chamber.
 - Gases are selected to have the following absorption ratio of incident x-rays; 10-30 % for IO chamber and 70-90 % for I chamber, respectively.
 - Gases are listed in the WEB site, <http://bl01b1.spring8.or.jp/RatioI0.html> and <http://bl01b1.spring8.or.jp/RatioI1.html>.
- Setup of measurement system
 - Set the beam size incident on the sample by slit opening.
 - Set the gain of current amplifiers (Amp) for each ionization chamber.
- Operation of program of Quick XAFS measurement
 - Set the following parameters in the operation program
 - ◇ Energy range and step for a XAFS spectrum
 - ◇ Total measurement time for a XAFS spectrum.

5. Preliminary process of XAFS spectra using software ATHENA

- The raw data of Quick XAFS spectra are processed to the ATHENA-readable data format.
- ATHENA processes the measured XAFS spectra, such as background removal and Fourier transforms.
 - ATHENA is one of most popular free software for processing XAFS data.
<http://cars9.uchicago.edu/~ravel/software/>
 - Model fitting of XAFS data is done by another software ARTEMIS including interfaces to ATOMS and FEFF.

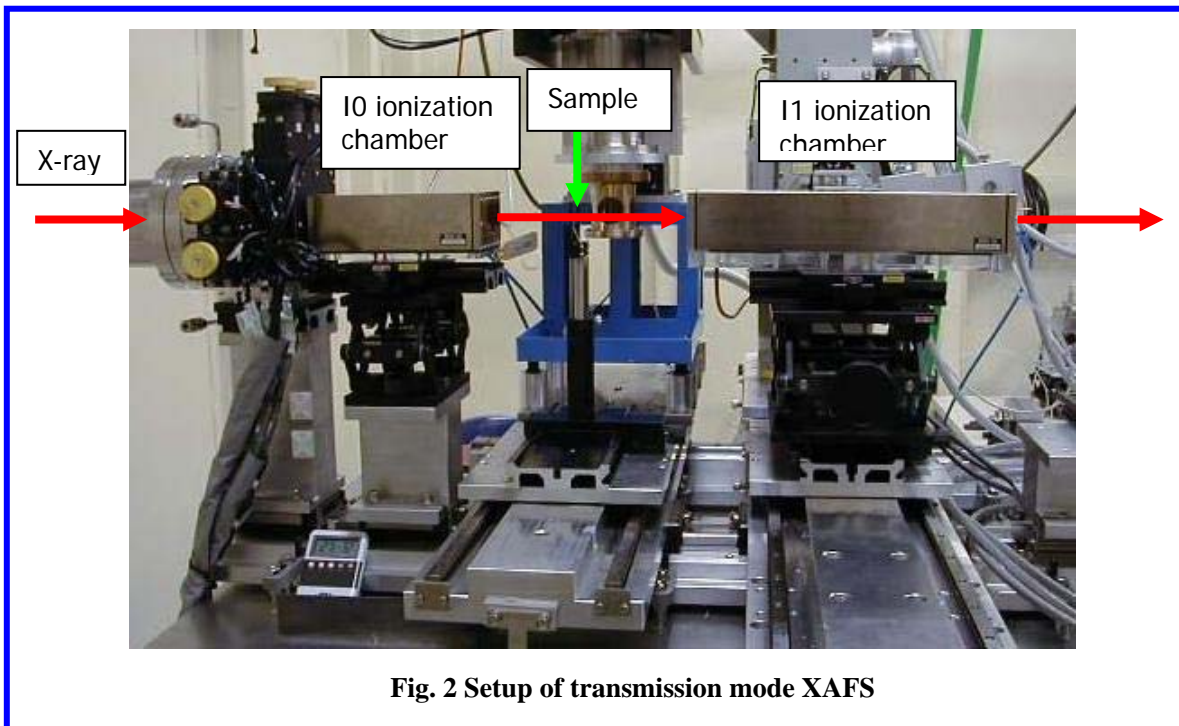

Fig. 2 Setup of transmission mode XAFS

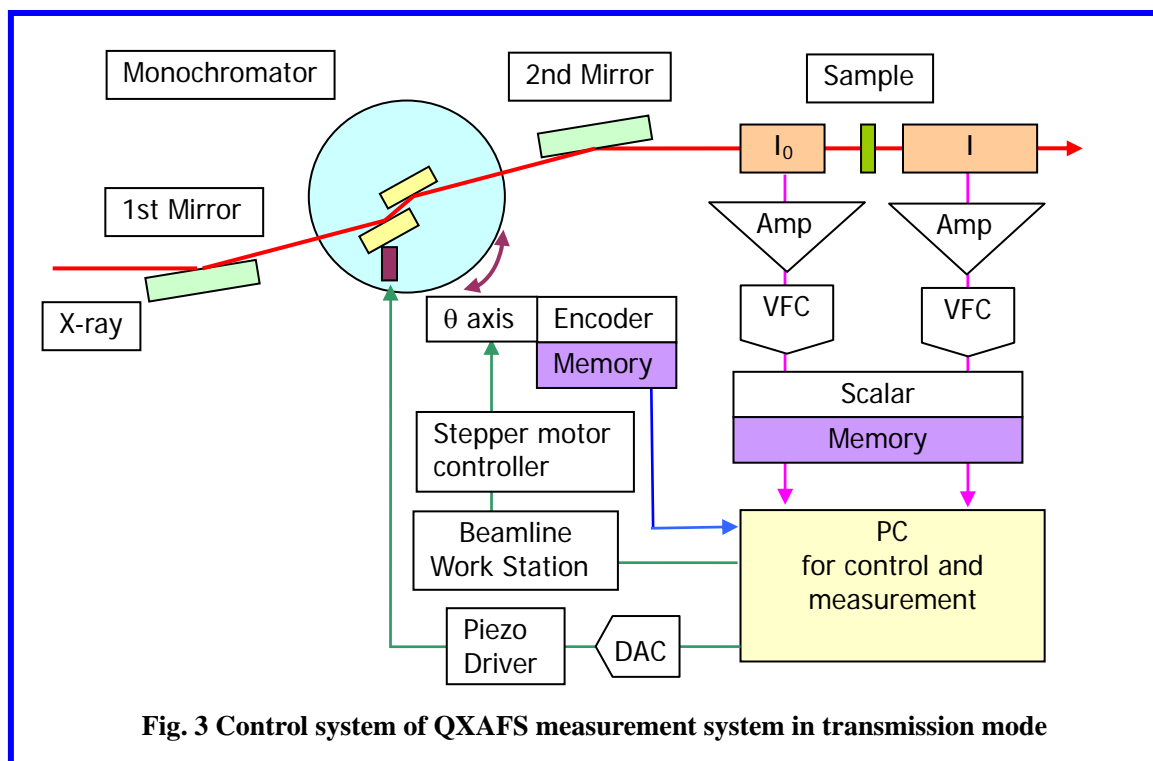

Fig. 3 Control system of QXAFS measurement system in transmission mode

6. Measurement of in-situ XAFS spectra in transmission mode

6.1 Sample preparation

- The sample for XAFS measurement is formed into thin disks of 7 mm diameter by press machine with very weak pressing force.
- Put adequate number of disk samples (around 20) into sample holder to achieve edge jump absorbance around 1.

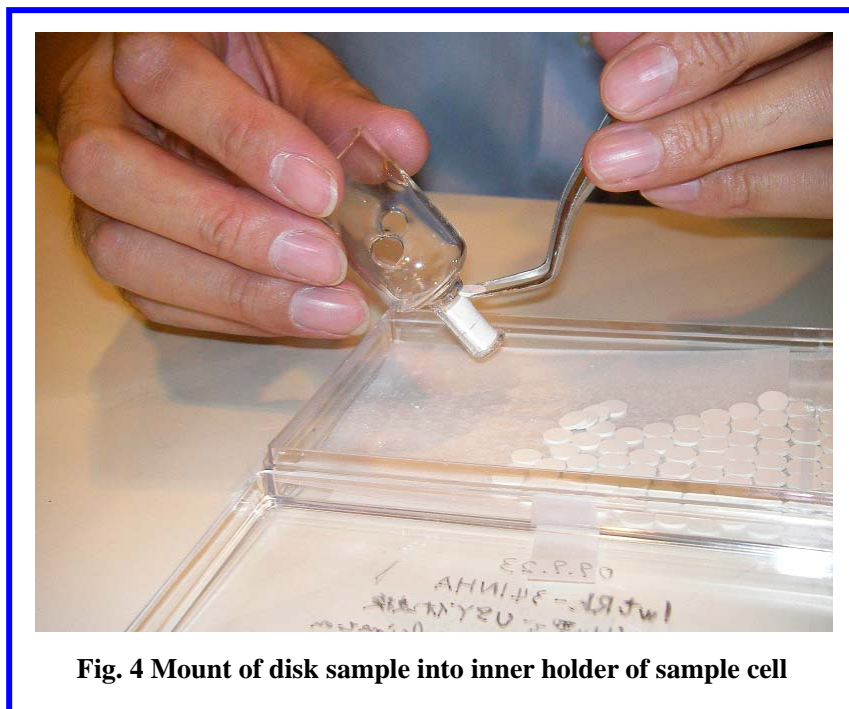

Fig. 4 Mount of disk sample into inner holder of sample cell

6.2 Setup of in-situ XAFS equipments

- Experimental condition in this in-situ measurement
 - Sample: Pd/USY catalyst
 - Measurement energy: around Pd K-edge (24.3 keV)
 - Sample temperature: room temperature
 - Reaction gases: H₂, O₂, He and their mixture
- Set the sample cell including disk samples.
- Connect Q-mass to outlet of sample cell to monitor the concentration of each outlet gas.

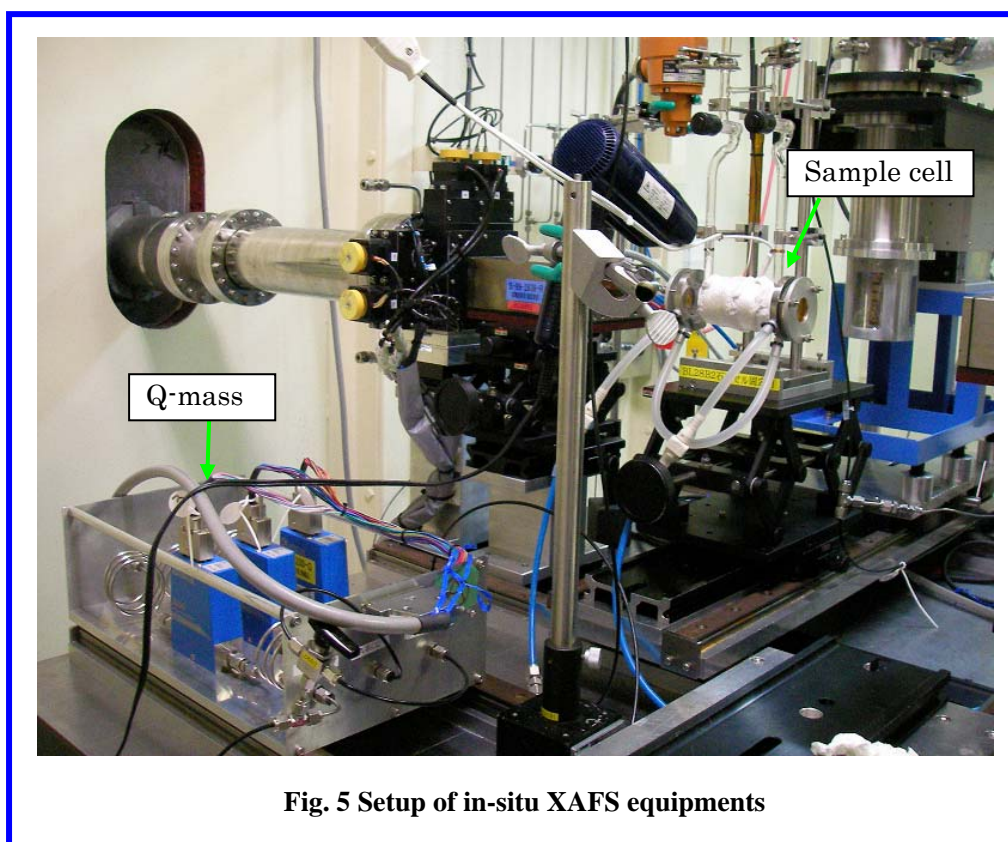

Fig. 5 Setup of in-situ XAFS equipments

6.3 In-situ XAFS measurement of catalyst during reduction process

- XAFS measurement of catalyst in initial state.
 - Flow 100%-He 90 ccm into sample cell.
 - Measure Quick XAFS spectra in transmission mode.
 - The measurement time of each XAFS spectra during this experiment is about 30 s.
- XAFS measurement of sample during reduction process.
 - Flow 8%-H₂/He 90 ccm (H₂: 7ccm, He: 83 ccm) into sample cell for 15-20 min.
 - Measure Quick XAFS spectra every 30 s during gas flow.
 - Check change of Fourier transform-XAFS spectra during reduction process using ATHENA.
 - Stop 8%-H₂/He flow.
 - Flow 100%-He for 10-15 min until no residual H₂ in sample cell (checking by Q-mass).
 - Measure Quick XAFS spectra.
 - Check the sample color.